

## 1 HEAD CRIMPING MACHINE

- Digital crimping machine for window sash and frames
- Assembling profiles of small or large dimensions
- Semi-automatic crimping on different types of profiles

AS1

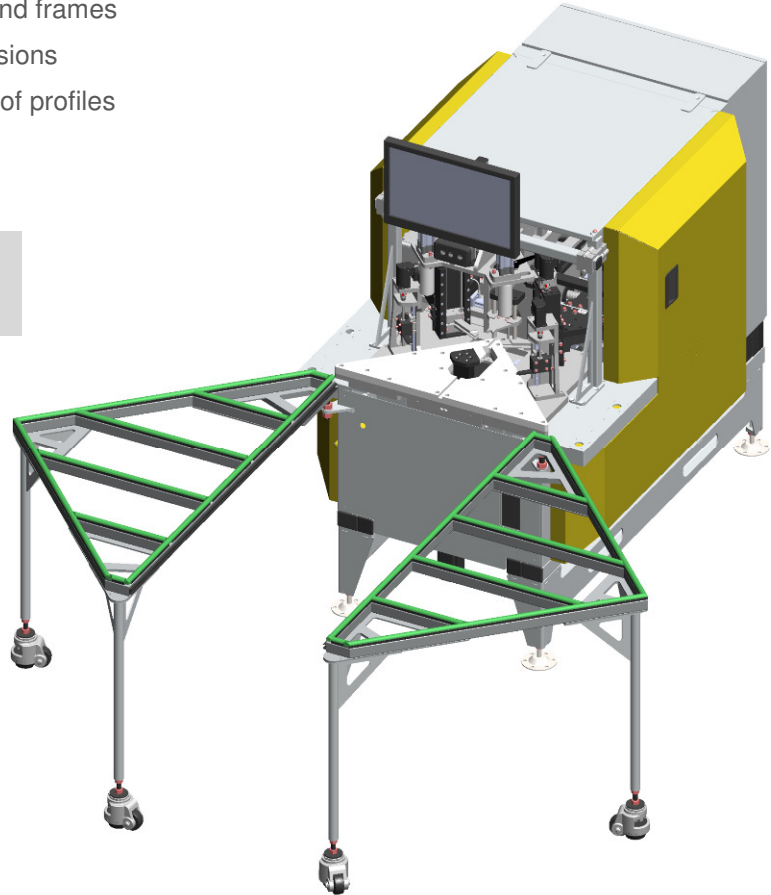

### TECHNICAL DATA

- Digital crimping machine with support table for pre-assembled frame
- GPAO data retrieval or manual selection
- Monitoring and adjustment of operations using Windows XP PC panel and barcode reader
- Multiple crimping: automatic combination of different heights, offsets and crimping depths at the same angle
- Passage of the whole production (sash and frames)
- Change of assembly configuration without machine adjustment (automatic configuration of the machine according to frame to be assembled, memorized and perfectly reproducible settings)
- Automatic height positioning of the centering V and lateral guides
- Automatic positioning of tools (height, depth, crimping angle)
- Maxi crimping height : 200mm
- Maxi profiles height : 250mm
- Dimensions of the mini frame : 220 x 220mm
- 45° Cutting angle
- Up to 10 digitized axes
- Different choices of support table (optional)
- Air pressure : 6 bars
- Power : 3,5 kW - 11A
- Supply voltage : 230 1-phase V + neutral + earth
- Dimensions of the machine (L x D x H) without the table : 1400 x 1700 x 1950mm
- Weight : 750 kg